



**Floating Differential Pressure
Electric Air Flow Switch
General Instructions**

For use with Schneider Electric reversible control actuators and for controlling differential pressures, static pressures or air velocities in duct systems.

Other Applications:

- Static pressure control in hospital white rooms.
- Draft and exhaust damper control.
- Liquid level control in closed tanks.

All metal construction with conduit opening, for 13 mm (1/2") conduit fitting. Has barbed connections for high and low pressure connections for 9 mm (3/8") O.D. tubing. Unit has SPDT floating contact, rated for 1.0 amps at 24 volts. Unit has integral arc suppression. Ambient temperature range: -29 to 60°C (-20 to 140°F). Has coded screw terminals. Mounts with diaphragm vertical on a vibration free surface. Dimensions: 130 mm (5-1/8") high, 120 mm (4-3/4") wide, and 111 mm (4-3/8") deep.

Option: None

ACCESSORIES

AP-301	Static probe for pressure .24 kPa (1" water) and up
AP-305	Static probe for pressures below .24 kPa (1" water)
AT-208	Duct mounting bracket for probes other than AP-301 and AP-305

INSTALLATION

Caution: These units are for use with air or non-combustible gases only.

Typical Actuators:

One Schneider Electric MP-300, -400, -2000 and -9700 series actuator directly. An AM-345 or AE-347 time delay relay is required for use with the MP-9200, -9400, -9600, and -9800 series actuator.

An SPDT floating switch action where "Common" makes to "Normally Closed" on a decrease in differential pressure between input ports, and to "Normally Open" on an increase in differential between input ports.

1. Select appropriate probes from Table 1.
2. Install probe. See Figure 4. Sampling probes should be located in areas of minimum air turbulence (6 to 8 duct diameters downstream from fan outlet, elbows, tees, or dampers). If this is not possible locate the probe tip as close to the center of the duct as possible.

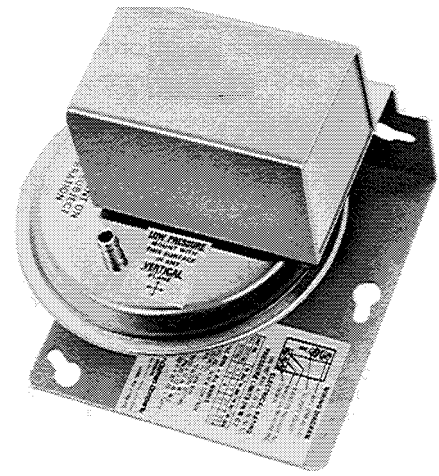

3. Mount the unit with mounting screws supplied. Note: The diaphragm must be mounted in a vertical plane in a location free from vibration. See Figure 3 for mounting details.
4. Connect the probe(s) to the pressure taps using the 3/8" O.D. plastic tubing supplied.
5. Make all connections in accordance with job wiring diagrams and in compliance with national and local codes.

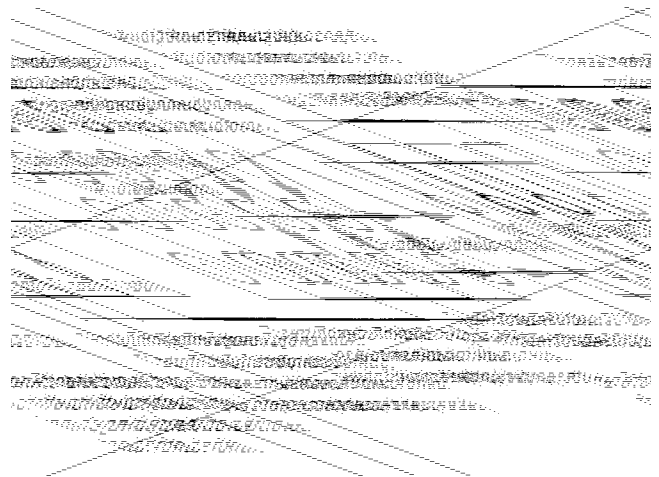

Figure-1 Typical Wiring.

Table-1 Specification Table.

Part Number	Differential Pressure Setpoint Range kPa (in. of water)	Adjustable Null Span*		Velocity Range M/S (FPM) 21°C (70°F) Air	Maximum Pressure
		At Minimum Setpoint kPa (in. of water)	At Maximum Setpoint (in. of water)		
PF-305	-12 to +12 (-.5 to +.5)	.01 to .03 (.06 to .14)	.01 to .03 (.07 to .14)	2 to 14 (400 to 2800)	Differential 3 kPa (12" Water) INPUT 7 kPa (28" Water)
PF-306	.04 to .32 (.2 to 1.3)	.01 to .03 (.05 to .13)	.03 to .06 (.13 to .28)	9 to 23 (1800 to 4600)	
PF-307	.27 to .87 (1.1 to 3.5)	.01 to .03 (.06 to .17)	.02 to .07 (.11 to .31)	22 to 38 (4200 to 7500)	
PF-308	.79 to 2.48 (3.2 to 10)	.02 to .09 (.12 to .4)	.06 to .19 (.24 to .8)	37 to 71 (7200 to 14000)	

* Min. null is with 127 μm (.005 in.) contact gap. Max null is 635 μm (.025 contact gap).

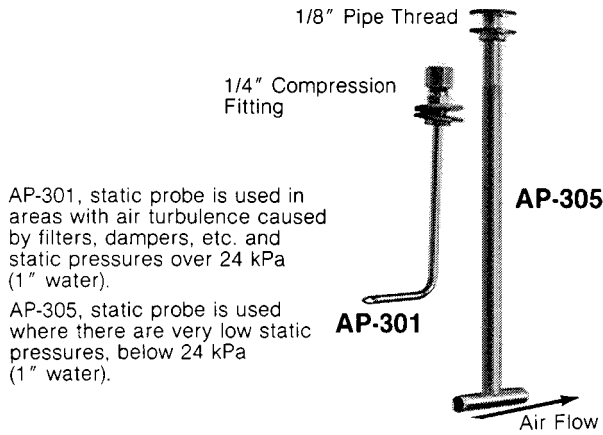

Figure-2 Optional Probes.

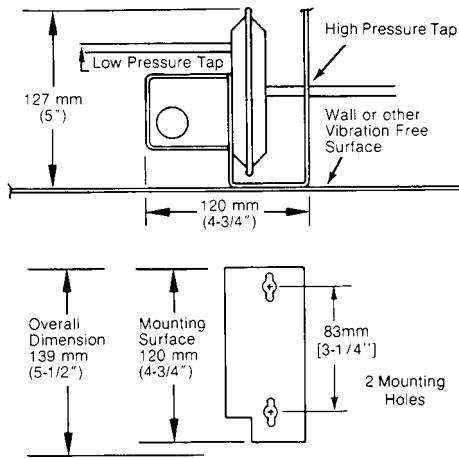

Figure-3 Mounting.

Table-2 Remote Mounting of Probe(s).

	Static	Velocity ^a	Total	ΔStatic	ΔTotal
High Press. Tap ^b	Probe 3	Probe 4	Probe 4	Probe 3	Probe 4
Low Press. Tap	—	Probe 3	—	Probe 3	Probe 4

^a Pilot can be used instead of two probes.

^b Highest (absolute) pressure should be applied to high pressure tap.

Δ = ΔDifferential.

Probes 3 and 4 (see Figure 4) can be constructed from 1/4 inch O.D., copper, brass, or aluminum tubing. The ends of the probes should be cut square to the sides of the tube and deburred. Total pressure probe must have the sensing end bent at 90° approximately 25 to 76 mm (1 to 3 inches) from the tip.

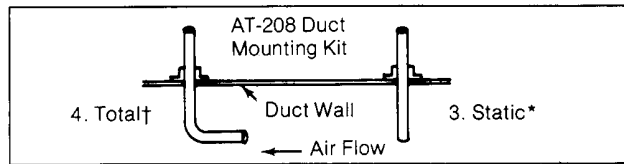

Remote Mounting of Probes. Use AT-208 to Mount Probe to Duct. (Above Items Not Supplied Order AT-208 Separately)

*Opening in tube must be perpendicular to air flow. These probes can accurately sense static pressure in smooth air at velocities up to 457 mpm (1500 fpm).

†Tips of probe must face directly into air stream.

Figure-4

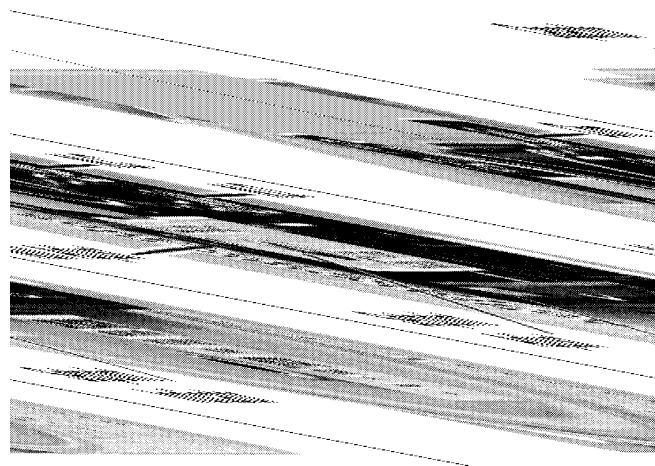

Figure-5

ADJUSTMENT

The locations for the setpoint and null span adjusting screws are shown in Figure 5. Factory settings as below:

Model	Setpoint kPa (inches water)
PF-305	.02 (.1)
PF-306	.17 (.7)
PF-307	.47 (1.9)
PF-308	1.49 (6)

Setpoint: Turn the setpoint screw CCW to increase if required.

Null Span: This is the pressure change in the duct without switch.

All models are factory set at the maximum null span; refer to Specification table. Turn the null adjustment screw CW to decrease if required.

FIELD REPAIR

Field repair is not recommended. If the system does not perform and the reason is traced to the control unit, it must be replaced.

On October 1st, 2009, TAC became the Buildings business of its parent company Schneider Electric. This document reflects the visual identity of Schneider Electric, however there remains references to TAC as a corporate brand in the body copy. As each document is updated, the body copy will be changed to reflect appropriate corporate brand changes.

Copyright 2010, Schneider Electric
All brand names, trademarks and registered
trademarks are the property of their respective
owners. Information contained within this
document is subject to change without notice.

F-17492-3

